

## PRODUCT DATA AND APPLICATION SHEET

**Product Name**      **Wall/Ceiling Fan**

**Product Code**      WF100, WF125, WF150

**Description**      These wall fans are ideal for toilets, bathrooms and laundry's. This product can be mounted to walls, windows and ceiling mounted. It has an integral backdraft shutter to prevent unwanted air from returning once switched off.

**Features**

- Slimline;
- IP40 rating;
- Includes back draft damper;
- This fan can preclude dusty, moist air, smoke and dust environments;
- Very limited noise levels with high performance;
- Easy installation.

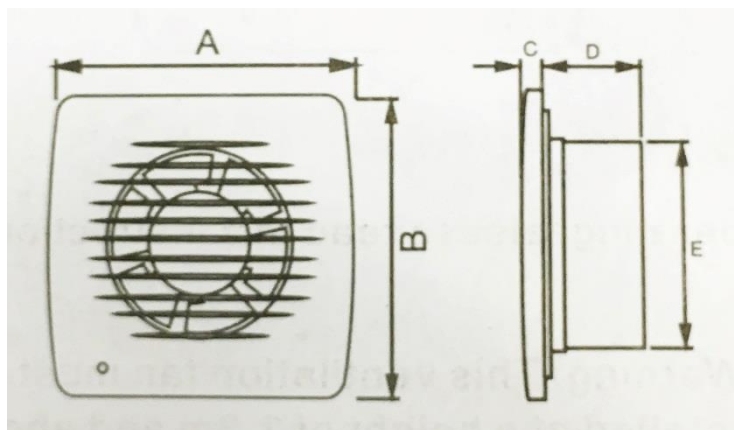

| Product Code | Specification | Rating voltage | Rating wattage | Rating wind       | Noise | Installation size A | Package dimension (mm) |     |    |     |    |
|--------------|---------------|----------------|----------------|-------------------|-------|---------------------|------------------------|-----|----|-----|----|
|              | mm            | V~/HZ          | W              | m <sup>3</sup> /h | dB    | mm                  | a                      | b   | c  | d   | e  |
| WF100        | 100           | 240/50         | 13             | 100               | 40    | Ø100                | 158                    | 158 | 25 | 98  | 55 |
| WF125        | 120           | 240/50         | 16             | 195               | 42    | Ø120                | 175                    | 175 | 28 | 115 | 55 |
| WF150        | 150           | 240/50         | 22             | 220               | 43    | Ø150                | 210                    | 210 | 30 | 150 | 55 |