

## PRODUCT DATA AND APPLICATION SHEET

**Product Name**      **Ceiling Fan**

**Product Code**      **CF200, CF250**

**Description**      Ceiling fans are the perfect accessory to enhance your interiors & compliment your lifestyle. Ceiling fans are perfect for the kitchen, toilets and bathrooms. Attractive slimline grille with efficient quite ball bearing motor.

**Features**

- Slimline Grille;
- Rust free fan;
- Efficient quite ball bearing, very limited noise levels with high performance;
- Easy installation;
- Standard 3 pin 240V plug for connection.

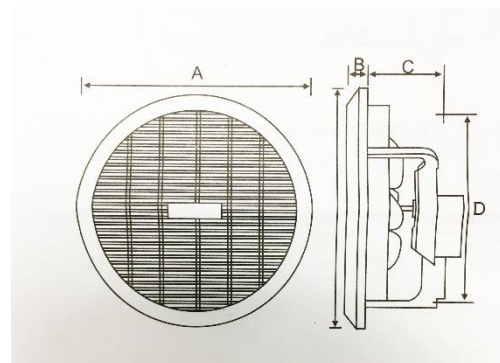

Product Code	Size	Volt	Frequency	Power	Capacity	Package dimension (mm)				
	mm	V	(Hz)	W	(m3/h)	a	b	c	d	e
CF200	200	240	50	28	250	298	20	78	242	123
CF250	250	240	50	38	300	350	20	76	296	121